

# SolarJet FL HD

Ultra high-speed laser marking and coding system



## Versatile

The SolarJet can be equipped with either pulsed fiber laser (SolarJet FL HD) emitting at 1.06  $\mu\text{m}$  or CO<sub>2</sub> lasers (SolarJet HDM) with three different wavelengths: 10.6  $\mu\text{m}$ , 10.2  $\mu\text{m}$  and 9.3  $\mu\text{m}$ .

## Easy to operate

The innovative Solaris Laser interface makes the system operation simple and friendly. User can work on a 15-inch touch screen or operate remotely from anywhere.



Metal cans



Crowns and lids



Organic materials



Beverage labels

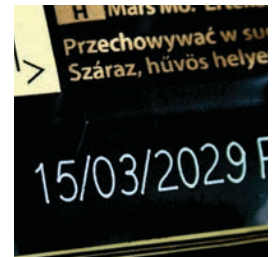

Flexible films



## Flexible

The SolarJet has a modular design and consists of three parts: scanning head, marking unit and control unit. Control unit and marking unit are connected with an umbilical with connectors from both ends. Beam bending module to fit into various production lines. operate remotely from anywhere.

## Industry 4.0 compatible

The SolarJet provides remote access to diagnostic features, such as system humidity and operating temperature. New Mark Good feature applies signal after correctly performed marking.



## Efficient

For 2 or more marking units configuration the SolarJet can be delivered with one master unit and a few slave units. Master has a remote access to the slave units.



**SOLARIS LASER**

a **DOVER** company

# SolarJet FL HD specifications

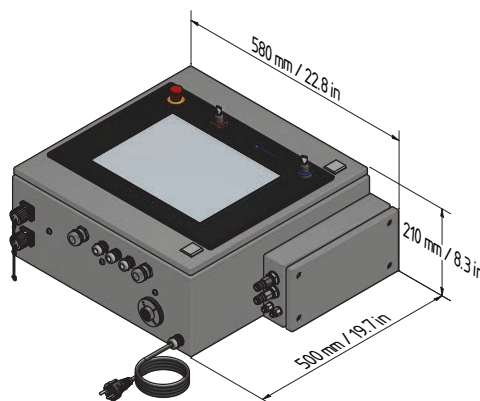
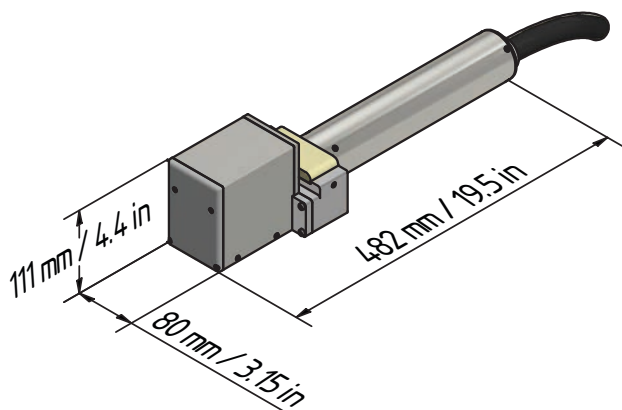

Laser type	Fiber laser: 1,06 μm
Marking field	From 60 x 60 mm to 300 x 300 mm
Software	Sol pad Job editing software for OS Windows 7,8,10, and 11
User interface	Multilanguage 15-inch touch screen with user friendly, intuitive interface for Preview, Edit & New jobs creation and System setup
Electrical requirements	115V / 230VAC, 50/60HZ, 1PH
Communications	RS232 / USB / Ethernet
I/O signals for installation	Shaft encoder, NPN/PNP Product detector inputs. Remote Interlock, Key switch, Safety shutter control. Fume extractor, Compressed air control. System ready, Marking, Fault outputs. 15 configurable user Inputs & Outputs
Cooling	Integrated water cooling
Ambient temperature	10-45 °C / 50-113 °F, Suggested 15-30 °C / 69-86 °F
Humidity	Up to 99%, non-condensing. IP 66
Safety	Class 4, according to EN 60825-1



CE and CDRH  
compliant



Solaris Laser Sp. z o.o.  
Farbiarska 39, 02-862 Warsaw, Poland  
Tel.: +48 22 843 18 03  
sales@solarislaser.com.pl  
www.solarislaser.com.pl